

DESIGN AND PERFORMANCE ANALYSIS OF OPTICAL CDMA SYSTEM USING NEWLY DESIGNED MULTIWAVELENGTH PRIME SEQUENCE CODES AT 1GBPS BIT RATE

Ms Gurjit Kaur

Senior Lecturer, ECE Department, Jaypee Institute of Information Technology University,
Noida, India

Email: gurjeet_kaur@rediffmail.com

Dr. Neena Gupta

Assistant Professor, E&EC Department, Punjab Engineering College, Deemed University,
Chandigarh, India

Email: ng65@rediffmail.com

ABSTRACT

This research work focuses to design OCDMA system with improved coding techniques which will help reduce hardware requirement and still offer better performance for higher number of users. These codes have been designed by remodeling and improvising the existing concept of Prime Sequence Codes. A three way correlation is derived between various input parameters e.g. bit rate, received power with respect to number of users and performance indicators *i.e.* BER and Quality factor. The codes designed result in improved performance compared to previous researches in terms of quality factor and bit error rate with minimum input requirements of power, bit rate etc for even in case of larger number of users. This system can support 21 users with -15db received power for 1Gbps bit rate for permissible bit error rate of e^{-9} . Moreover these results are more realistic as practical impairments have also been considered.

Keywords-Multiple Access Interference (MAI), Optical Code Division Multiple Access (OCDMA)

1 INTRODUCTION

OCDMA is an essential part of the digital communication system now days for long haul, high speed LAN and MAN networks [1]-[3]. The biggest challenge with Optical CDMA system is to maintain the performance of the system and offer high bandwidth in case of higher number of users at minimum cost. As the number of users increase, the input requirements *i.e.* transmitted power, bit rate etc start increasing sharply which contribute to the additional cost [3]-[5]. In this research the available 2D codes under the OCDMA system were studied and with a view to overcome the limitations in terms of expanding the user base (number of users, speed of the system, bit error rate, quality factor, required received power etc.), a new code set have been introduced based on rigorous analysis.

These codes have been designed by remodeling and improvising the existing concept of Prime Sequence Codes. The above mentioned code sets have then been used for implementing the OCDMA system by way of simulation for a fiber length of 60km for

MAN network, keeping into consideration all other possible practical disturbances *i.e.* transmitter, channel, receiver noise etc. The performance evaluation of the system has been done by designing a realistic simulation setup which has proximate relationship with the practical parameters and scenario.

2. CODING ARCHITECTURE

The code design is based on the prime sequence code pattern. One code from prime sequence family becomes the master code in new code design set which also fixes the time slot pattern while wavelength as the other dimension is varied with various combinations according to prime sequence code family. The specialty of this coding technique is the generation of a large number of code set by using a low code weight value. *i.e.* three. This technique uses delay lines which are similar to each other for implementation of encoder which reduces the complexity and makes the system more cost effective. In this coding structure, seven mode locked lasers along with three time delay lines are used to design forty nine codes.

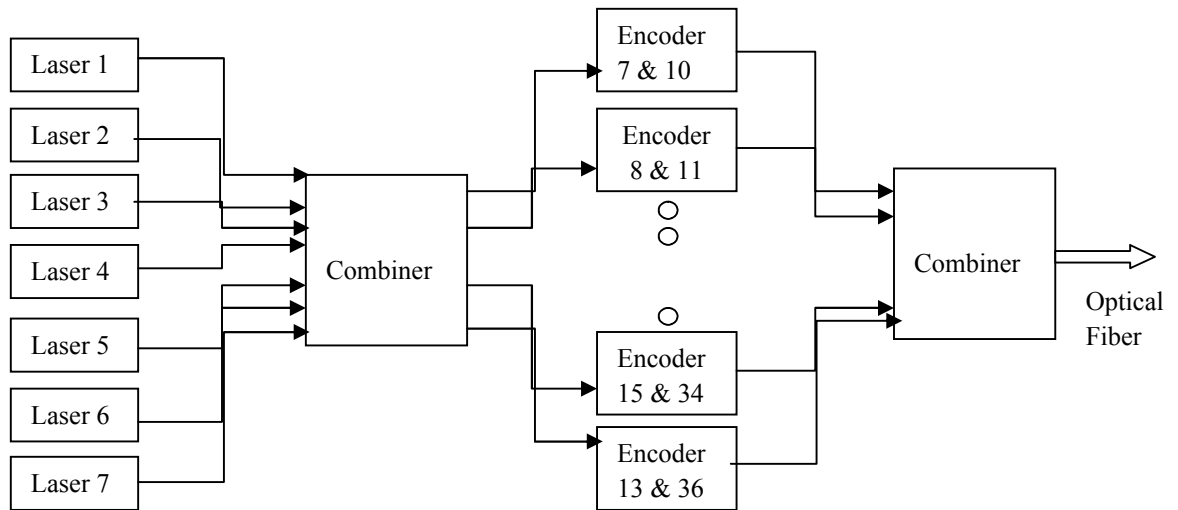

Figure 1: OCDMA Transmitter Design

The first seven codewords of group G1 are mapped as C1: $\{\lambda_1, \lambda_1, 0, \lambda_1, 0, 0, 0\}$, C2: $\{\lambda_2, \lambda_2, 0, \lambda_2, 0, 0, 0\}$... C7: $\{\lambda_7, \lambda_7, 0, \lambda_7, 0, 0, 0\}$ whereas the next seven codewords of G2 are mapped as C8: $\{\lambda_1, \lambda_2, 0, \lambda_3, 0, 0, 0\}$, C9: $\{\lambda_2, \lambda_3, 0, \lambda_4, 0, 0, 0\}$... C14: $\{\lambda_7, \lambda_1, 0, \lambda_2, 0, 0, 0\}$. Similarly seven groups each consisting of seven codewords form a complete set of 49 codewords.

3. OCDMA SYSTEM DESIGN

To implement both the coding techniques, a realistic simulation model for OCDMA system is designed which considers all practical impairments e.g. transmitter, channel and receiver noise etc. while analyzing the performance of designed codes as shown in Figure 1. Two different encoders are designed after confirming the viability of the system.

The performance of the codes is evaluated using this simulation model by varying number of users at different received power i.e. -15db to -30db for various data rates. As per the requirement of codes constructed seven lasers have been used at the transmitter end as represented in Figure 1. The NRZ pulses are used for designing the OCDMA system as shown in Figure 2. Each codeword consists of three wavelengths to form

one code as represented in Figure 3 and 4. Figure 5 represents the receiver section of the OCDMA system.

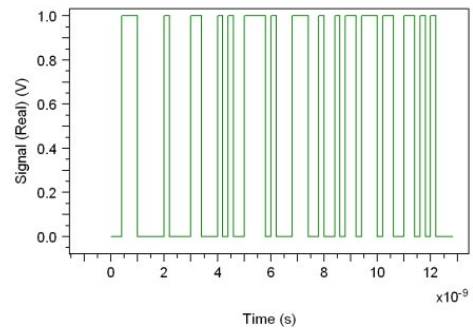

Figure 2: Signal diagram for 1Gbps at PRBS generator

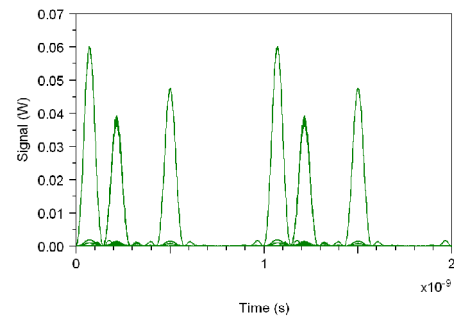

Figure 3: Eye diagram at encoder for 1Gbps

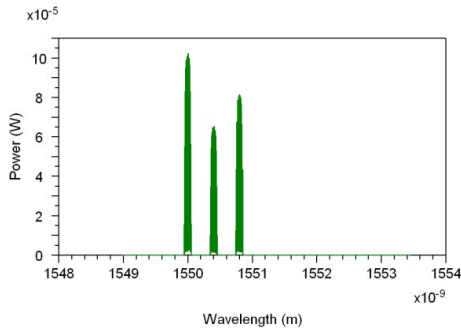

Figure 4: Wavelength Spectrum at encoder for 1Gbps system

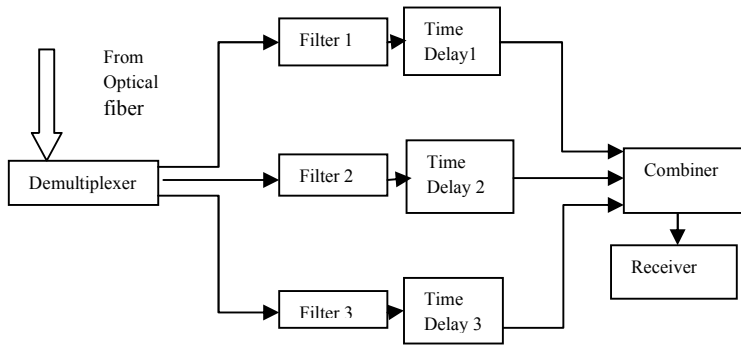

Figure 5: Decoder design for 1Gbps OCDMA system

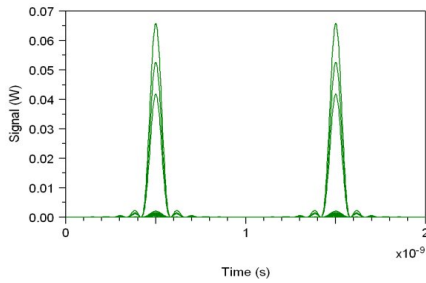

Figure 6: Eye diagram at decoder 1 for 1Gbps system

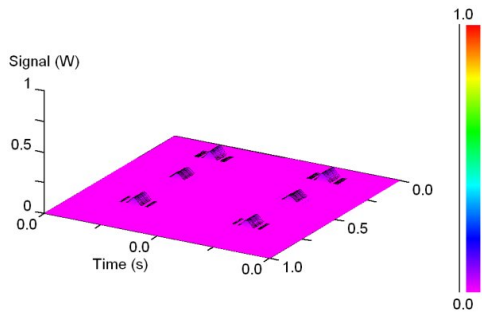

Figure 7: 3D view of eye diagram for 1Gbps system

The decoders in the receiver section realign the pulses as depicted in Fig. 6 and 7. Avalanche photo diode is used in the receiver section. Fig. 8 represents the signal output from the receiver. This signal diagram shows the degraded signal at the destination. But still, the 1Gbps stream has survived the journey quite well because of the loss incurred in channel.

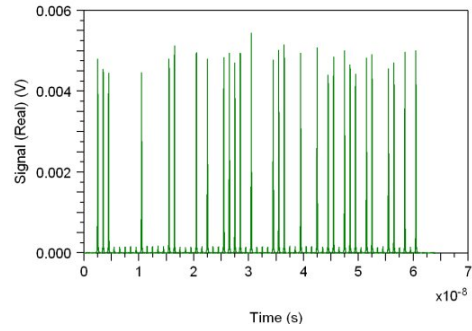

Figure 8: Signal diagram at receiver 1 for 1Gbps system

4. RESULTS AND DISCUSSIONS

The results in the form of signal diagrams in Fig. 9 to 14 depict that as the number of users increases from 1 to 5, the multiple access interference pulses starts rising along with the original pulses.

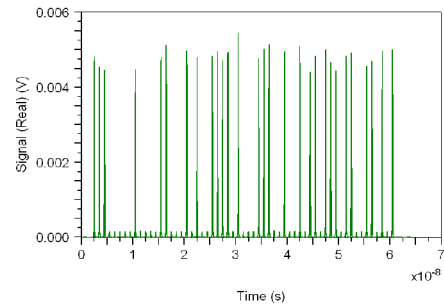

Figure 9: Signal diagram for single user

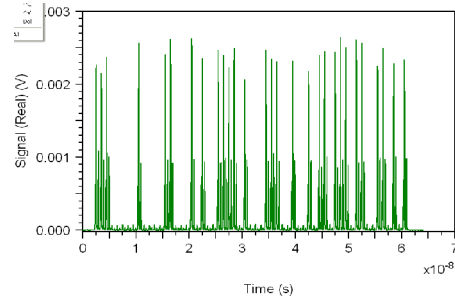

Figure 10: Signal diagram for 2 users

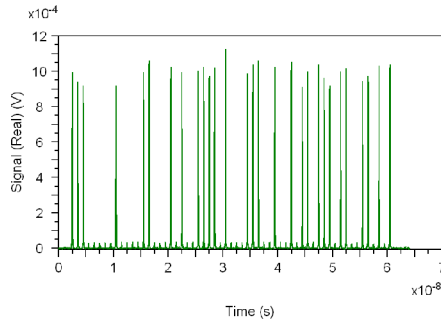

Figure 11: Signal diagram for 5 users

The signal in the signal diagram is still clear upto five users as represented in Figure 9 to 11 which means that the noise is within the acceptable limit. From the signal diagrams in Fig. 12 to 14, it is observed that as the number of users increases from 8 to 22, the multiple access interference further increases. The multiple access interference pulses start growing up to the level of original pulses which can give a wrong detection as represented in Fig. 14. Also the amplitude of the signal decreases with increase in number of simultaneous users. For 8 users the maximum amplitude of the signal is 6.5×10^{-4} V which degrades to 4×10^{-4} V for 22 users as represented in Fig. 12 and Fig. 14.

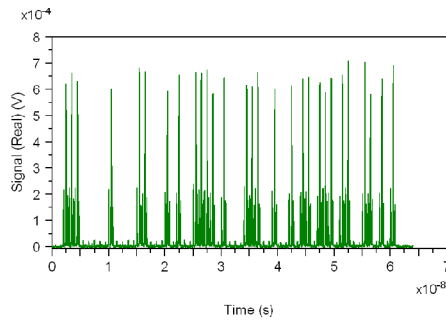

Figure 12: Signal Diagram for 8 users

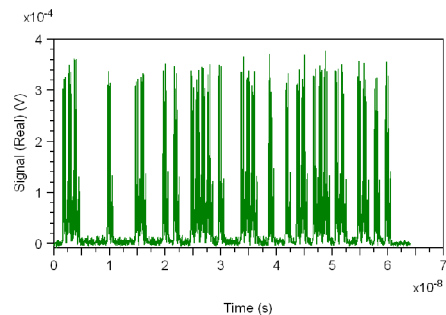

Figure 13: Signal Diagram for 16 users

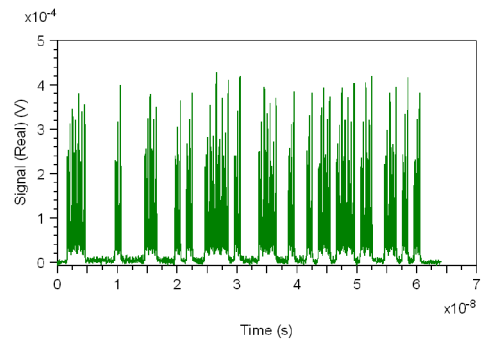

Figure 14: Signal diagram for 22 users

The performance of the new architecture is also evaluated in terms of bit error rate versus the number of simultaneous users at different received power as represented in Fig. 15.

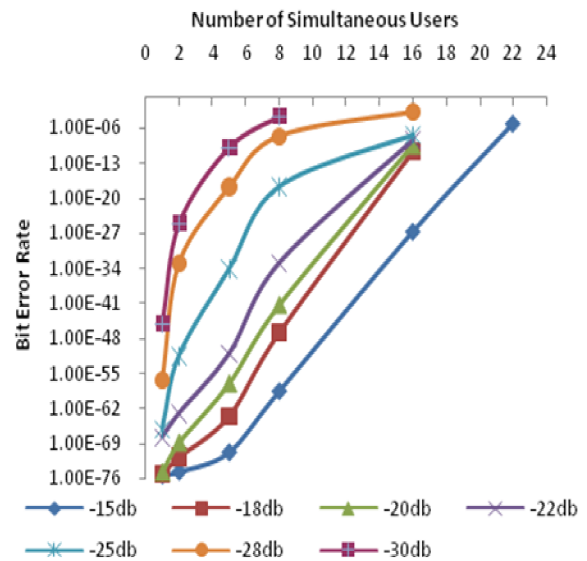

Figure 15: Bit error rate versus number of simultaneous users at different received power for 1Gbps system

The system performance is outstanding for -15db received power and can accommodate 21 simultaneous users for bit error rate of e^{-9} . Therefore, it can be inferred that the system performance is better when received power is higher. As the received power decreases from -15db to -30db the bit error rate also decreases from e^{-71} to e^{-10} for 5 users.

The quality factor analysis shown in the Fig. 16 represents that as the number of simultaneous users increases the quality factor degrades.

REFERENCES

- [1]. Vincent J. Hernandez, Antonio J. Mendez, Corey V. Bennett, Robert M. Gagliardi and William J. Lennon, "Bit-Error-Rate Analysis of a 16-User Gigabit Ethernet Optical-CDMA (O-CDMA) technology Demonstrator Using Wavelength/Time Codes", IEEE Photonics Technology Letters, Vol.17, No. 12, pp. 2784-2786 (2005).
- [2]. V. Baby, I. Glesk, R.J. Runser, R. Fisher, h. Yue-kai, C.S. Bres, W.C. Kwong, T.H. Curtis and P.R. Prucnal, "Experimental demonstration and scalability analysis of a four node 102 Gchip /s fast frequency hopping time spreading optical CDMA network", IEEE photonics Technology Letter, Vol. 17, No. 1, pp. 253-255 (2005).
- [3]. J. Faucher, R. Adams, L. R. Chen, and D.V. Plant, "Multiuser OCDMA system demonstrator with full CDR using a novel OCDMA receiver," IEEE photon technology letter, Vol. 17, No. 5, pp. 1115-1117 (2005).
- [4]. A.J. Mandez, V.J. Hernandez, C.V. Bennett, R.M. Gagliardi, and W.J. Lennon, "Demonstration of record BER and number of users for optical CDMA (OCDMA) with implications to secure communications", VCRL-CONF-210103.
- [5]. Simon Ayotte, Leslie A. Rusch, "Experimental comparison of coherent sources in a four user λ -t OCDMA system at 1.25 Gb/s", IEEE photonics technology letters, Vol 17, No 11, pp-2493-2495 (2005).

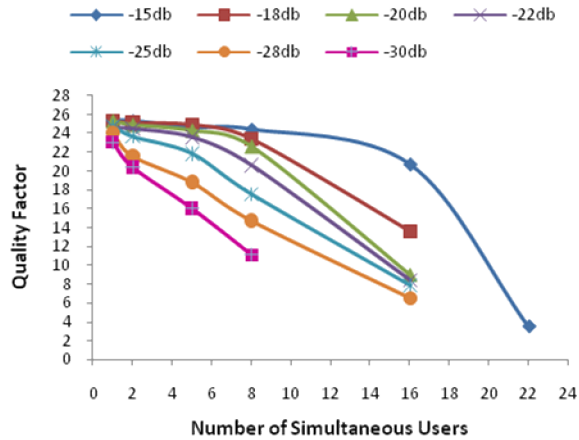

Figure 16: Quality factor versus number of simultaneous users at different received power for 1Gbps MPSC based OCDMA system

For single user the quality factor changes from 25.3 to 23 with the decrease in received power from -15db to -30db, which means lesser rate of change in the quality factor for lesser number of users. But as the number of users increases from 1 to 8 the quality factor degrades from 24.4 to 11.1 with the received power variation of -15db to -30db. For the same received power of -15db the rate at which quality factor degrades is very low *i.e.* 25.3 to 24.4 for one to eight users but as number of users' increases to sixteen or twenty two the quality factor degrades at a higher rate *i.e.* 24.4 to 3.49.

5. CONCLUSION

The OCDMA system designed for this new coding architecture, results in improved performance compared to previous researches in terms of quality factor and bit error rate with minimum input requirements of power, bit rate even in case of larger number of users. Moreover these results are more realistic as practical impairments have also been considered. With -15db received power and for permissible BER of 10^{-9} this OCDMA system can accommodate up to 21 users at 1Gbps bit rate. If received power is kept lower *i.e.* -22db, the same system can accommodate 16 users for 1Gbps bit rate.

6. ACKNOWLEDGMENT

The authors are extremely thankful to Optoelectronics laboratory of PEC Deemed University, Chandigarh for providing the necessary support in this research.